



Safetech

Safetech Cranes

Plant :

Chhawchharia Engineering Pvt. Ltd.
C-19, 20&21, Adityapur Industrial Area
Phase - 3, Jamshedpur- 832109
Jharkhand, Ph. : +91 93346 15554

Corporate Office :

21, Ballygunge Circular Road,
Unit 20, CPC Complex, 3rd Floor,
Kolkata - 700 019 West Bengal
Mobile : +91 98307 82627
E-mail : info@safetechgroup.net / saurabh@safetechgroup.net
Website : www.safetechgroup.net



Safetech is the safest in Material Handling

Safetech

Safe Admired Fastgrowing EngineERED by TECHnology

Safetech

Safetech Is The Safest In Material Handling



SAFE and smooth material handling

» MOVING MATERIAL RESOURCES SAFELY WITH CARE

Safetech Single Girder and Double Girder E.O.T. Cranes are designed and manufactured in accordance with IS:3177 and IS:4137. Considering adequate factor of safety with respect to appropriate duty. The structural parts of the cranes are designed in Accordance with IS:807. Safetech also manufactures cranes as per international standards. Safetech cranes are manufactured with standard components and controls to ensure reliability.



Single Girder Type E.O.T. Cranes

> Span
3 mtrs to 30 mtrs

> Safe Working Load
500 kgs to 20,000 kgs

» Crane Control
From floor through Pendant Push Buttons, Optionally through Radio Remote Control / cabin with master control

» Power Supply System
To Hoist and Cross Travel through Trailing Cables / Drag Chain To Crane through Shrouded Bus Bars / Trailing Cable / MS Angle Iron Conductors / Bare Copper Conductors (depending on customer's choice and application)

» Motors
Squirrel Cage & Slip Ring Motors based on application requirements, built-in separator electrically operated fail safe brakes for all three motions. Motors with 'F' class insulation provided in all motions.

» Drive System
Accordance with IS:3177 Mech, Structural Parts IS:807, Others Miscellaneous Parts IS:3177, Steel Plant IS:4137.

» Speeds
Selected depending on client specifications / applications / shed dimensions

» Class of Duty / Standards
Equivalent to M3, M5, M7, M8 as per IS 3177 / IS 807

> Span
5 mtrs to 75 mtrs

> Safe Working Load
500 kgs. to 2,00,000 kgs.

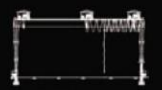
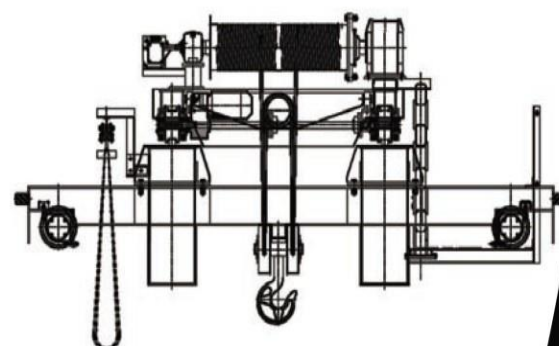
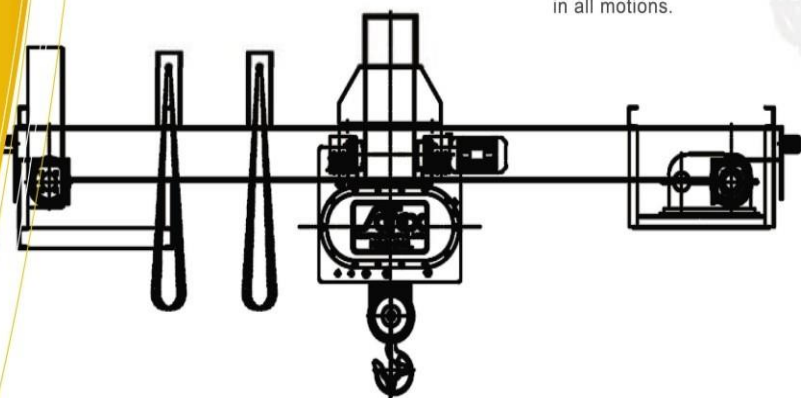

Goliath Cranes

Gantry / Goliath Cranes are adapted to applications where overhead runways would be very long, costly to erect, and difficult to maintain in alignment. Where the installation is only temporary, a gantry crane can be moved to a new location with less trouble or expenses than an overhead crane and its runway.



Our Clients

Shiv Shambhu Iron & Steel Co. Ltd.
R. K. Enterprises (P) Ltd.
Macnecil Engineering India Ltd.



Semi Goliath Cranes

We are engaged in manufacturing qualitative range of semi goliath cranes that are used to carry heavy load applications. It has wide usage in construction industry, shipping yards, road sides, mines, quarries and many other industries. Designed using the latest technology, these are highly cost effective and requires minimum maintenance.

FROM THE DESK OF THE CEO

of the founders of **Safetech Cranes**, I proudly take this opportunity to introduce ourselves as pioneer in manufacturing of material handling equipments in India. In 2007, I envisioned that we want to enable manufacturing industries which can propagate safest material handling equipments with excellent quality. Safety is the key element in material handling and excellent quality is the basic requirement for long life of the equipments. Safetech has developed and marketed wide range of products, all founded on the same basic philosophy of safest and excellent in all engineering means, that is what has made Safetech brand name across the globe.

Our beginning was certainly meager, with a little more than 10 employees but with hard work and dependence on the key values such as optimum trust of our customers, quality of our products and engineering excellence, we have grown to become a trademark within the industry. Today, we employ more than 50 dedicated employees within Safetech family. Safetech manufactures material handling equipments such as Single Girder E.O.T. Cranes, Double Girder E.O.T. Cranes, Goliath Cranes, Semi Goliath Cranes, Jib Cranes, Cage Hoists Arrangement, Electric Wire Rope Hoists, Flameproof Hoists, Chain Hoists, Chain Pulley Blocks and many more.

With this amalgam of experience and general commercial success; we have made sure to continue our attention to the people who has made our business a success story. So far, we have served more than 100 customers on Global basis with successful installations of more than 22000 equipments. We are manufacturing, supplying and exporting quality products all over the world including big names like TISCO LTD, Tata Motors Ltd., Defence Factories, Hyva India Ltd (A Dutch MNC) Vendanta Group (UK).

We push towards a future in which we have become the world leader in material handling equipments and a trademark for all businesses that require material handling equipments to facilitate their businesses. I am heartily thankful to all my global clients for their immense and prolonged reinforcement in our success.

Yours Sincerely,
Saurabh Chhawchharia
 CEO

Index

» EOT Cranes



Single Girder EOT Cranes | Double Girder EOT Cranes

Goliath Cranes



Semi Goliath Cranes | Goliath Cranes

» Hoists



Wire Rope Hoists | Flame Proof Hoists

Cranes / Hoists



Jib Cranes | Cage Hoists Arrangement

» Chain Hoists



Chain Pulley Blocks | Chain Hoists



Single Girder Type E.O.T. Cranes

Single Girder EOT (Electric Overhead Traveling) Crane is mostly suitable for up to 10t. Cap., 20 meters span and class-II, duty it consists of standard Sections fabricated or box type plate fabricated beam, wheels, Gearboxes, motors, and running overhead to lift materials and run both axis.



Our Clients

Mal Mateliks Pvt. Ltd.
 Sngnal Projects (P) Ltd.
 BPA Projects Ltd.



Double Girder Type E.O.T. Cranes

These girders are of box type construction with butt-weld joints in tension zone radio graphed. These cranes also have totally enclosed oil splash lubricated gear box with precision machine cut gears pinions.

The wheels of this crane are made of Forged steel. The wheel assemblies are provided on 'L' type bearing housing with anti friction spherical roller bearings



ADMIRER for long life

» MOVING MATERIAL RESOURCES SAFELY WITH CARE

Safetech make Goliath cranes are designed & manufactured in accordance with IS: 3177 and IS: 4137. Considering adequate factor of safety with respect to appropriate duty. The structural parts of the cranes are designed in Accordance with IS: 807. Safetech also manufactures cranes as per international standards. Safetech cranes are manufactured with standard components and controls to ensure reliability. Our wide range of goliath cranes are useful for handling material resources for various industries and projects.



Semi Goliath Cranes Goliath Cranes

> **Span**
 5 mtrs to 20 mtrs

> **Safe Working Load**
 1000 kgs. to 30,000 kgs.

> **Crane Control**
 From floor through Pendant Push Buttons, Optionally through Radio Remote Control / cabin with master control

> **Power Supply System**
 To Hoist and Cross Travel through Trailing Cables / Drag Chain To Crane through Shrouded Bus Bars / Trailing Cable / MS Angle Iron Conductors / Bare Copper Conductors (depending on customer's choice and application)

> **Motors**
 Squirrel Cage & Slip Ring Motors based on application requirements, built-in separator electrically operated fail safe brakes for all three motions. Motors with 'F' class insulation provided in all motions.

> **Drive System**
 Accordance with IS:3177 Mech, Structural Parts IS:807, Others Miscellaneous Parts IS:3177, Steel Plant IS:4137.

> **Speeds**
 Selected depending on client specifications / applications / shed dimensions

> **Class of Duty / Standards**
 Equivalent to M3, M5, M7, M8 as per IS 3177 / IS 807

> **Span**
 5 mtrs to 50 mtrs

> **Safe Working Load**
 1000 kgs. to 60,000 kgs.



Wire Rope Hoists

SAFETECH Wire rope hoists are designed in modular construction which greatly simplifies repairs & cuts down-time. The special features are low head room, spur/helical gears running on antifriction ball bearings with oil bath lubrication, motors conforming to IS325, "fail to safe" breaks which automatically operates in case of any power failure, tested wire rope conforming to IS:2266, forged hooks conforming to IS:3815.



Our Clients

Tata Motors Ltd
 Defence Factories in India
 Hyva India Ltd (A Dutch MNC)

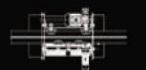

Flameproof Hoists

flame proof hoists are manufactured in wide range like lifting capacities between 250 kgs. to 20,000 kgs., lifting height up to 50 mtrs., with various types of cross travel trolleys like power travel type, hand geared travel, push pull trolley, flexible trolley to negotiate even a small radius etc.

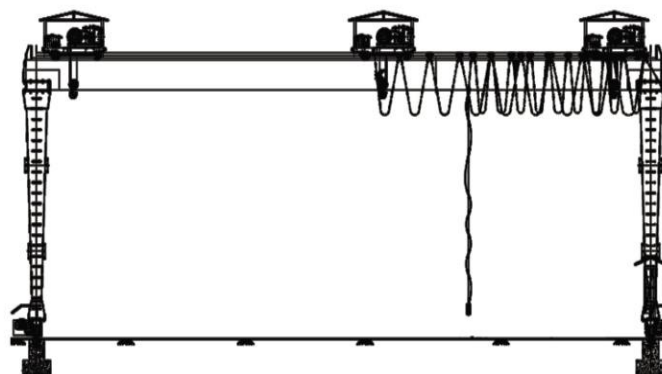
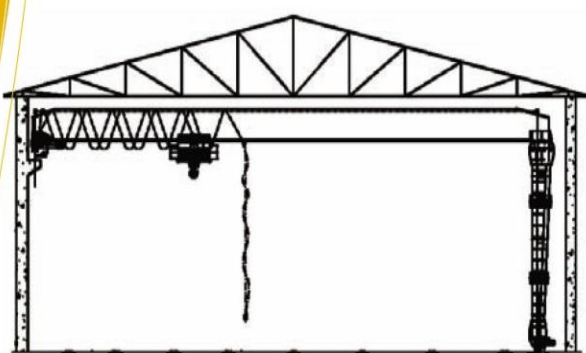



ENGINEERED WITH TECHNOLOGY

▶ MOVING MATERIAL RESOURCES SAFELY WITH CARE

Safetech jib cranes meet the most demanding material handling requirements. There are various jib crane models from which to choose: floor-mounted pillar types; top and bottom-supported units; wall or column-mounted versions, and models that afford manual or motorized rotation. Built to the highest industry standards. Safetech jib cranes have earned a reputation for ruggedness and durability.

Both types of lifts are suitable for wall type canopy as well as self-supporting steel structure. Safetech has unique arrangement of providing four "T" guides for balanced loading and guide rollers for smooth and efficient drive. The goods lift is being Safetech operated by push button station fixed outside the cage on respective floors.



- ▶ Floor level Ground level + 10
- ▶ Pay Load Capacity 500 kgs. to 5000 kgs.

Jib Cranes Cage Hoist Arrangement

- ▶ Radius 2 mtrs to 6 mtrs
- ▶ Safe Working Load 250 kgs. to 5,000 kgs.
- ▶ Class of Duty / Standards Equivalent to M5, M7, M8 as per IS 3177 / IS 807
- ▶ Crane Control From floor through Pendant Push Buttons, Optionally through Radio Remote Control / cabin with master control

▶ **Power Supply System**
To Hoist and Cross Travel through Trailing Cables / Drag Chain To Crane through Shrouded Bus Bars / Trailing Cable / MS Angle Iron Conductors / Bare Copper Conductors (depending on customer's choice and application)

▶ **Motors**
Squirrel Cage & Slip Ring Motors based on application requirements, built-in separator electrically operated fail safe brakes for all three motions. Motors with 'F' class insulation provided in all motions.

▶ **Drive System**
Accordance with IS:3177 Mech, Structural Parts IS:807, Others Miscellaneous Parts IS:3177, Steel Plant IS:4137.

▶ **Speeds**
Selected depending on client specifications / applications / shed dimensions

▶ The floor doors are provided with mechanical and electrical locking arrangement. Hence unless floor door is closed properly, lift cannot be started. Additional gravity limit switch is provided for extra safety. In case of failure of over hoisting limit switch, power will be cut off by gravity limit switch upon over traveling of the cage.

▶ Every single rope is having rated capacity with min. 6 F.S. which in four fall construction will provide four times the required F.S. Hence even in case of breakage of 3 wire ropes out of 4. the cage will not fall. This is extra safety over any other conventional similar type goods lift.

▶ The cage is made of rolled steel sections and sides are covered with bumped sheets. Cage top is covered with M.S. Sheets and bottom is covered with chequered plate for antiskid property. Collapsible doors are provided on cage as per entry and exit position. The cage is being guided with rollers on "T" guide rail. Antifriction bearings are provided for smooth and efficient traveling with low friction and longer life.

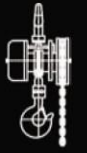
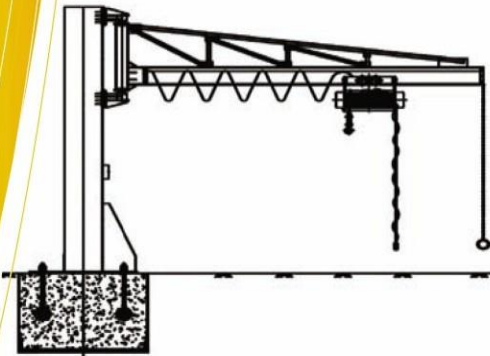
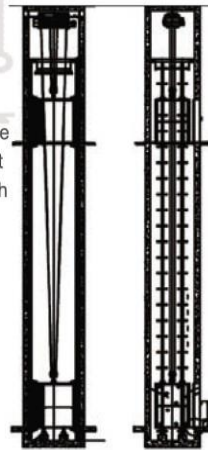

Chain Pulley Blocks

Safetech chains pulley blocks are designed & manufactured in accordance with IS:3832 & are available in hook suspension type; push-pull trolley type hand geared trolley type. Load chain used is graded alloy steel chain & hand chain is m.s. calibrated to relevant Indian standards and international standards.



Our Clients

- Cebcco Ltd
- Utkal Automobiles Ltd
- B D Ispat & alloys pvt Ltd



Chain Hoists

Safetech electric chain hoists are designed in modular construction for easy maintenance. The special features like low headroom, spur gears running on antifriction ball bearings with oil bath lubrication, motors conforming to IS 325 etc. make. Safetech chain hoists unbeatable to its price. Safetech chain hoists are available in hook suspension type; push pull trolley type, hand geared trolley type.



EXCELLENCE is what we aim for

▶ MOVING MATERIAL RESOURCES SAFELY WITH CARE

Safetech chains pulley blocks are designed & manufactured in accordance with IS 3832 & are available in Hook suspension type; push-pull trolley type hand geared trolley type. Load chain used is graded alloy steel chain & hand chain is m.s. calibrated to relevant Indian standards and international standards.

Safetech electric chain hoists are designed in modular construction for easy maintenance. The special features like low headroom, spur gears running on antifriction ball bearings with oil bath lubrication, motors conforming to IS 325 etc. make. Safetech chain hoists unbeatable to its price. Safetech chain hoists are available in hook suspension type; push pull trolley type, hand geared trolley type, power travel trolley type and flexible trolley type to negotiate small radius.



- ▶ Safe Working Load Capacity upto 15 Tons

Chain Pulley Blocks Chain Hoists

- ▶ Safe Working Load Capacity upto 15 Tons

- ▶ Low Headroom
- ▶ Positive Transmission (Bearing Supporter)
- ▶ Lubrication: Totally enclosed gear case is packed with sufficient grease
- ▶ Concentrated design for high substance
- ▶ The chain hoist is tested at 125% overload before dispatch
- ▶ Quality Designed forged steel top and bottom hooks
- ▶ Precision shaped load sheave is mounted to assure minimum wear and smooth operation

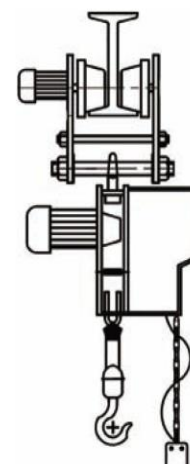
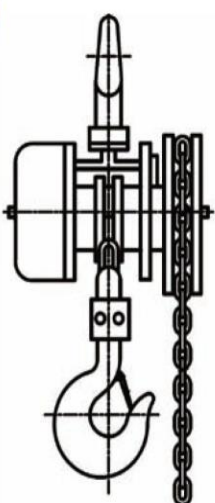

Quality of Products

Beyond a stellar attention to customer service and excellence in engineering, we at Safetech ensure that the utmost in quality is applied to all means of production, supplying, and exporting of all our material handling equipments.



Our Clients

- Universal Auto Components Ltd
- Rupa Engineering pvt ltd
- Hitech Engineers
- Wim Plast Ltd



Services

We arrange selection and installation procedure for Gantry Rails and Gantry Girders for Single Girder Type E.O.T. Cranes, Double Girder Type E.O.T. Crane and Goliath / Gantry Cranes.



For the FASTGROWING companies

MOVING MATERIAL RESOURCES SAFELY WITH CARE

Safetech Wire rope hoists are designed in modular construction which greatly simplifies repairs & cuts down-time. The special features are low head-room, spur / helical gears running on antifriction ball bearings with oil bath lubrication, motors conforming to IS 325, "fail to safe" breaks which automatically operate in case of any power failure, tested wire rope conforming to IS 2266, forged hooks conforming to IS 3815 and push button stations operating at step down voltage of 110 V: 42 V or 24 V.

Safetech flame proof hoists are manufactured in wide range like lifting capacities between 250 kgs. to 20,000 kgs., lifting height up to 50 mtrs., with various types of cross travel trolleys like power travel type, hand geared travel, push pull trolley, flexible trolley to negotiate even a small radius etc.



> Class of Duty / Standards
IS:3938 and IS:2148

> Safe Working Load
250 kgs. to 20,000 kgs.

Wire Rope Hoists Flame Proof Hoists

> Safe Working Load
500 kgs. to 20,000 kgs.

Crane Control

From floor through Pendant Push Buttons, Optionally through Radio Remote Control / cabin with master control

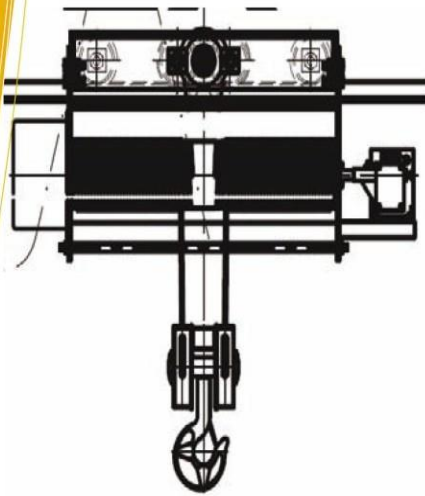

Power Supply System

To Hoist and Cross Travel through Trailing Cables / Drag Chain To Crane through Shrouded Bus Bars / Trailing Cable / MS Angle Iron Conductors / Bare Copper Conductors (depending on customer's choice and application)

Motors

Squirrel Cage & Slip Ring Motors based on application requirements, built-in separator electrically operated fail safe brakes for all three motions. Motors with 'F' class insulation provided in all motions.

Class of Duty / Standards

Equivalent to IS 3938

Speeds

Selected depending on client specifications / applications / shed dimensions

Drive System

Drive through Squirrel Cage Induction Geared Motors with built-in fail safe brakes

Safetech flame proof hoists are designed in modular construction which greatly simplifies repairs and cuts down time. Safetech flame proof hoists are designed in accordance with IS-3938. All electrical apparatus are housed in flame Proof enclosures conforming to IS - 2148 and mechanical components are designed so that there is no ferrous metal to ferrous metal contact in order to void any chance of sparking. Hence flame proof hoists are flame proof as well as spark proof.

Safetech flame proof hoists are offered for gas group I, IIA and IIB suitable for zone -1 and zone - 2 areas whereas for gas group IIC flame proof hoists are offered only for zone-2 areas.

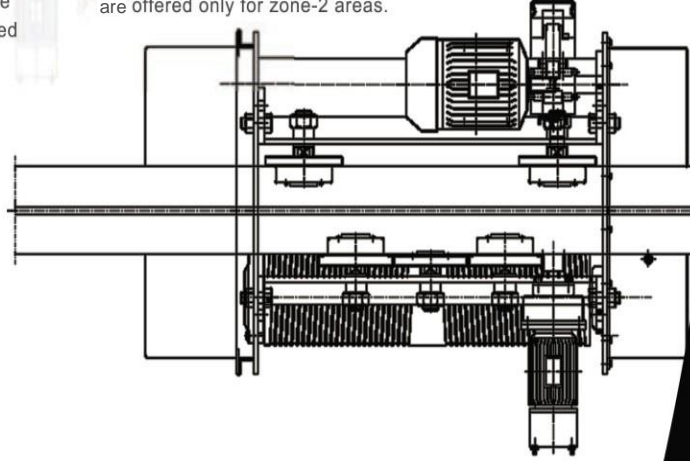

Cage Hoist Arrangement

Both types of lifts are suitable for wall type canopy as well as self-supporting steel structures. Safetech has unique arrangement of providing four "T" guides for balanced loading and guide rollers for smooth and efficient drive. The goods lift is being operated by push button station fixed outside the cage on respective floors.



Our Clients

Vendanta Group (UK)
TISCO LTD
Vinar Systems India Ltd

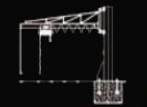

Jib Cranes

There are various jib crane models from which to choose: floor-mounted pillar types; top and bottom-supported units; wall or column-mounted versions, and models that afford manual or motorized rotation. Built to the highest industry standards. Safetech jib cranes have earned a reputation for ruggedness and durability

Quality and Services

Quality policy

Safetech Cranes is manufacturer of material handling and electrical equipments in flame proof enclosures which are designed as per agreed specifications and timely supplying quality product to satisfy the customer with continuous improvement in product and service with motivated and committed work force and effectively complying Quality Management System.

Quality of our products

Beyond a stellar attention to customer service and excellence in engineering, we at Safetech ensure that the utmost in quality is applied to all means of production, supplying and exporting of all our material handling equipments. To deliver quality products:

- > We perform alignment of trolley and crane wheels, leveling and measuring, analysis of results, strength calculations for safe operations of crane.
- > We provide Testing Certificates for all the crucial parts required for the all type of cranes.
- > In-house Testing Capabilities for up to 150-200 tonnes.

Internal quality audits

One of the best ways that we can get across our attention to quality to someone considering our services is not just through our words; but through the strict accreditation of internal quality audits that come with being ISO 9001:2000 certified. ISO 9001:2000 means Companies that are accredited with this certification have been strenuously and continuously audited as regards how their qualitative product is being created and engineered. The International Organization of Standardization has many strict requirements that a company must satisfy in order to receive this certification, of which the following apply:

- > Procedural conduct for all key processes in the business.
- > Process monitoring for effectiveness.
- > Maintaining internal records.
- > Reviewing output for defects with corrective action where necessary.
- > Reviewing on a regular basis individual processes and the quality system to ensure the optimum in efficacy is obtained.
- > Striving towards improvement at all legs of the company's existence.

Our services

- > We arrange selection and installation procedure for Gantry Rails and Gantry Girders for Single Girder Type E.O.T. Cranes, Double Girder Type E.O.T. Cranes and Goliath / Gantry Cranes.
- > We perform design of columns for supporting the Gantry Girders, design of Monorails and supports for Electric Hoists.
- > We contribute selection of the control system for the equipment as per the client's usage.
- > We provide selection and sizing of Down Shop Leads for Hoists and E.O.T. cranes, sizing of Cable Reeling Drums and cables of Goliath / Gantry cranes.
- > We arrange selection and sizing of incoming cables and protective equipment and economic routing, based on workshop architecture.
- > We carry out Erection and Commissioning of Cranes, Hoists, Cage Hoists (Goods Elevator), Chain Pulley Blocks and rails. We also provide Gantry Alignment readiness and refurbishment of old Cranes.
- > We provide Load Testing and Certification of the Material Handling Equipments.



Custom Solutions

Safetech has history of designing material handling equipments for any kind of hazardous environment. We have succeeded where others have failed. We provide Custom solution to any material handling requirement.



Our Clients

Toro processors India pvt.ltd
Tech trade
Newco auto pvt.ltd
and many more under pipeline.



Contact Us

Plant :
Chhawchharia Engineering Pvt. Ltd. C-19, 20&21, Adityapur Industrial Area Phase - 3, Jamshedpur- 832109 Jharkhand, Ph. : +91 93346 15554
Corporate Office :
21, Ballygunge Circular Road, Unit 20, CPC Complex, 3rd Floor, Kolkata - 700 019 W.B.
Mobile : +91 98307 82627
E-mail : info@safetechgroup.net saurabh@safetechgroup.net
Website : www.safetechgroup.net